

NOTES

CHECK AND CONFIRM ALL EXISTING LEVELS ON SITE PRIOR TO COMMENCING ANY WORKS. REPORT ANY DISCREPANCIES OR ERRORS TO THE ARCHITECT PRIOR TO PROCEEDING AND SEEK AN INSTRUCTION.

BUILDER SHALL VERIFY ALL DIMENSIONS ON SITE PRIOR TO COMMENCEMENT OF THE PRODUCTION OF ANY SHOP DRAWINGS OR THE MANUFACTURE OF ANY ELEMENTS AND REPORT ANY DISCREPANCIES TO THE ARCHITECT BEFORE PROCEEDING AND SEEK AN INSTRUCTION.

ALL WORKMANSHIP AND MATERIALS TO BE IN ACCORDANCE WITH THE LATEST RELEVANT SAA CODES, BUILDING REGULATIONS AND BUILDING CODE OF AUSTRALIA.

DO NOT SCALE DRAWINGS.

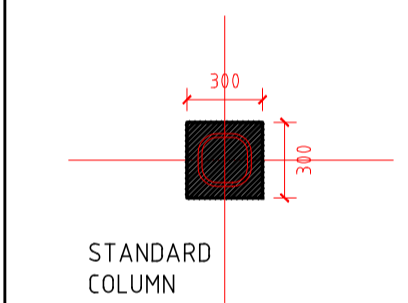

REV	DETAILS	DATE	BY
2	ISSUED FOR REVIEW	23/09/14	HD
1	ISSUED FOR REVIEW	22/09/14	HD

mcg architects pty ltd
 JCY architects and urban designers

CLIENT
 CITY OF BUSSELTON

PROJECT TITLE
 BUSSELTON ADMINISTRATION
 AND CIVIC CENTER
 2 SOUTHERN DRIVE
 BUSSELTON

DRAWING TITLE
 SECOND FLOOR PLAN

DESIGN	DATE	PROJECT NUMBER	REV
DRAWN	SCALE	1313	2
<small>THIS DRAWING IS AND SHALL REMAIN THE PROPERTY OF "mcg architects pty ltd" AND MAY ONLY BE USED FOR THE PURPOSE FOR WHICH IT WAS COMMISSIONED AND MAY NOT BE COPIED, REPRODUCED OR DISTRIBUTED WITHOUT WRITTEN PERMISSION OF THE OWNER.</small>		DRAWING NUMBER	
		SK03	

